

DOUBLE ACTING PNEUMATIC CYLINDERS WITH LOCK DEVICE

VDMA 24562, NF E 49003.1



Cylinders are designed to meet the specifications of international standard VDMA 24562 for mounting. The cylinders can work in higher temperatures by request. Fully adjustable cushioning at end of stroke is available. Lock device is actuated by spring force and deactivated by compressed air. Lock device is self-locking.

Lock device is not a safety element! The user must take relevant safety precautions!



1



Warning

Clamping force is purely static. When exceeding load, slipping of piston rod may occur, or piston rod and/or lock device can be damaged. Right connection and suitable designed control is necessary for impact free work. Please consult your connection with our technical dept.

| | |
|--------------------------------|-------------------------|
| Working pressure | 0,6 MPa |
| Min. pressure | 0,15 MPa |
| Max. pressure | 1,0 MPa |
| Min. pressure for lock release | 0,2 MPa |
| Locking direction | both direction |
| Temp. range | -20°C to +80°C * |
| Working medium | modified compressed air |

*) values are valid for standard gaskets

| Piston diameter [mm] | 32 | 40 | 50 | 63 | 80 | 100 | 125 |
|---|--------|--------|--------|--------|--------|--------|--------|
| Thrust at 0,6 MPa [N] | 482 | 754 | 1178 | 1870 | 3015 | 4713 | 7363 |
| Thrust at 0,6 MPa [N] with double ended piston rod | 415 | 633 | 990 | 1682 | 2720 | 4418 | 6880 |
| Return force at 0,6 MPa [N] | 415 | 633 | 990 | 1682 | 2720 | 4418 | 6880 |
| Static clamping force [N] | >482 | >754 | >1178 | >1870 | >3015 | >4713 | >7363 |
| Connection | G1/8" | G1/4" | G1/4" | G3/8" | G3/8" | G1/2" | G1/2" |
| Length of adjustable cushioning [mm] | 13 | 13 | 11 | 16 | 16 | 20 | 25 |
| Max. stroke [mm] * | 1000* | 1000* | 1000* | 1000* | 1000* | 1000* | 1500* |
| Weight 0 mm stroke [kg] | 1,15 | 1,62 | 2,80 | 3,90 | 6,20 | 9,80 | 20,6 |
| Weight add. per 1 mm stroke [kg] | 0,0028 | 0,0037 | 0,0060 | 0,0062 | 0,0100 | 0,0110 | 0,0160 |
| Weight 0 mm stroke [kg] with double ended piston rod | 1,25 | 1,72 | 3,00 | 4,10 | 6,90 | 10,60 | 22,4 |
| Weight add. per 1 mm stroke [kg] with dbl. ended piston rod | 0,0038 | 0,0047 | 0,0080 | 0,0082 | 0,0140 | 0,0150 | 0,0220 |

*) Stroke of cylinder may be longer after agreement with our technical dept.

Order codes

10110 60 00 050 0100

| Type | | Equipment | | Options | | Piston diameter | | Stroke / Repair kit | |
|-------|---|-----------|---|---------|-----------------------------------|-----------------|--------|---------------------|---|
| 10110 | DIN ISO 6431, VDMA 24562, NF E 49003.1, double acting, with lock device | 00 | w/o cushioning, w/o magnet | 00 | without options | 032 | 32 mm | xxxx | mm of stroke e.g.: 0100 = stroke 100 mm |
| | | 05 | double ended piston rod, w/o cushioning, w/o magnet | 10 | Viton® piston rod sealing | 040 | 40 mm | | |
| | | 10 | w/o cushioning, with magnet | 11 | Viton® gaskets (up to 180°C) | 050 | 50 mm | | |
| | | 15 | double ended piston rod, w/o cushioning, with magnet | 13 | round tube* | 063 | 63 mm | | |
| | | 50 | with cushioning, w/o magnet | 14 | 1.4301 stainless steel piston rod | 080 | 80 mm | | |
| | | 55 | double ended piston rod, with cushioning, w/o magnet | | | 100 | 100 mm | | |
| | | 60 | with cushioning, with magnet | | | 125 | 125 mm | 9999 | repair kit |
| | | 65 | double ended piston rod, with cushioning, with magnet | | | | | | |

*) Only valid for piston dia. 32 to 100 mm included

For more options regarding materials or dimensions, please contact our technical dept.

Construction / materials

- caps: drawn dural profile, anodised, piston dia. 100: aluminium casting, anodised
- body: drawn dural profile, anodized
- piston rod: ground round steel bar CK45 with hard chrome plated surface

Dimensions

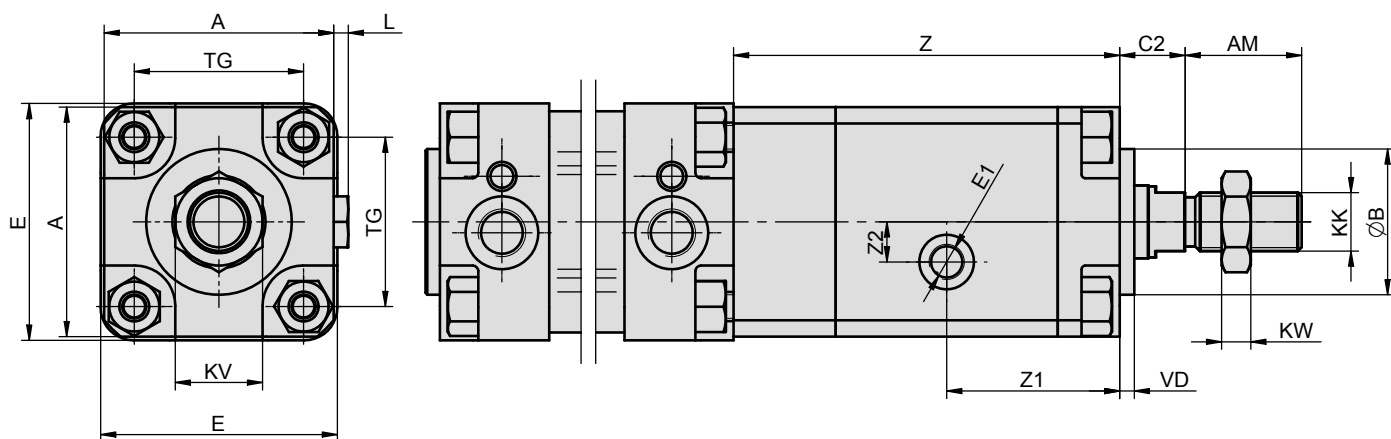

| ∅ | A | AM | B | C2 | E | E1 | KK | KV | KW | L | TG | VD | Z | Z1 | Z2 |
|-----|-----|----|----|------|-----|-------|----------|----|----|---|------|----|-----|------|----|
| 32 | 45 | 22 | 30 | 13,5 | 48 | G1/8" | M10x1,25 | 16 | 5 | 4 | 32,5 | 4 | 95 | 47 | 5 |
| 40 | 56 | 24 | 35 | 16 | 55 | G1/8" | M12x1,25 | 18 | 6 | 4 | 38 | 4 | 107 | 49,5 | 9 |
| 50 | 63 | 32 | 40 | 18 | 65 | G1/8" | M16x1,5 | 24 | 8 | 4 | 46,5 | 4 | 106 | 46,5 | 11 |
| 63 | 70 | 32 | 45 | 18 | 75 | G1/8" | M16x1,5 | 24 | 8 | 4 | 56,5 | 4 | 116 | 52,5 | 11 |
| 80 | 90 | 40 | 45 | 18 | 94 | G1/8" | M20x1,5 | 30 | 10 | 5 | 72 | 5 | 150 | 65 | 18 |
| 100 | 110 | 43 | 55 | 18 | 115 | G1/8" | M20x1,5 | 30 | 10 | 5 | 89 | 5 | 158 | 66,5 | 18 |
| 125 | 140 | 54 | 60 | 22 | 140 | G1/4" | M27x2 | 30 | 13 | - | 110 | 5 | 255 | 106 | 0 |

For dimensions of pneumatic cylinder on which the lock device is attached, see page 1-5.

Connection example for pushbutton control:

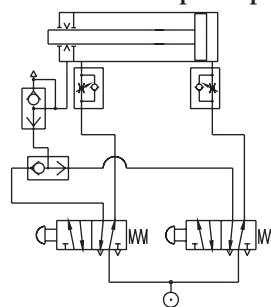

Pressing the left pushbutton, the lock unit will unclamp and air which flows through right push-button into cylinder will extend it. After release pushbutton, compressed air is released from lock unit, which clamps piston rod and cylinder stops. For quick stopping of cylinder, the quick exhaust valve is used. The im-

portant on this connection is, that both chambers of cylinder are still with compressed air and for motion control discharging of air from particular chambers is used, which prevents from impacts or unwanted countermovements.

Mounting accessories

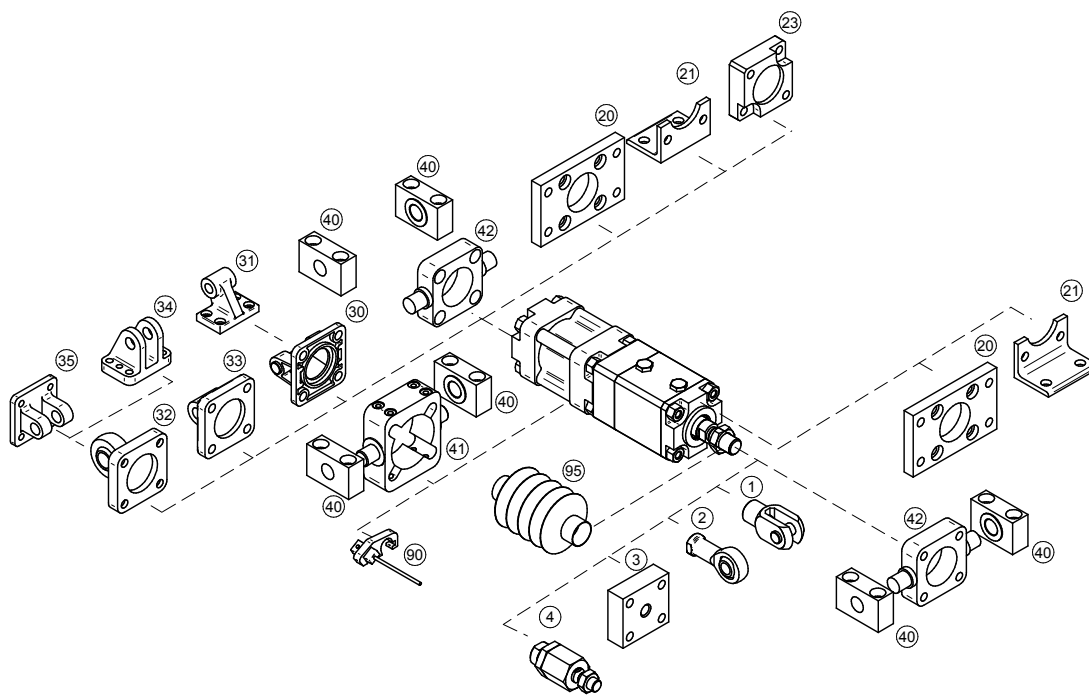

| Mounting accessories | ... see page |
|---|-------------------|
| 1 Piston rod clevis | ... 4-2 |
| 2 Piston rod eye | ... 4-3 |
| 3 Flanged piston rod coupling | ... 4-2 |
| 4 Self-aligning piston rod coupling | ... 4-3 |
| 20 Flange mounting | ... 4-5 |
| 21 Foot mounting | ... 4-5 |
| 23 Boxer flange mounting | ... 4-6 |
| 30 Swivel flange | ... 4-7 |
| 31 Clevis foot mounting | ... 4-7 |
| 32 Swivel flange with spherical bearing | ... 4-8 |
| 33 Swivel flange | ... 4-8 |
| 34 Narrow swivel flange | ... 4-9 |
| 35 Rectangular swivel flange | ... 4-9 |
| 40 Trunnion mounting | ... 4-10 |
| 41 Pivot pin | ... 4-11 |
| 42 Pivot pin to front/end cap | ... 4-12 |
| 90 Prox. switch | ... 3-2, 3-4, 3-7 |
| 95 Piston rod protective cover | ... 4-4 |